

RAK410 Serial WIFI Module Datasheet

Content

RAK410 Serial WIFI Module Datasheet.....	1
1 Overview	3
1.1 General Description	3
1.2 Applications	3
1.3 Devices Features	3
1.4 RAK410 System Block Diagram	4
2 Functional Description.....	4
2.1 Host Interfaces.....	4
2.2 WLAN	5
2.3 Network Protocols	5
2.4 Configuration	5
3 Hardware	6
3.1 Package Dimensions	6
3.2 Reference Design	7
3.3 Recommended Reflow Profile	9
3.4 Baking Instructions	9
4 Pin Descriptions	10
4.1 Module Pinout (Top View)	10
4.2 Pin Description.....	10
5 Electrical Characteristics	12
5.1 Absolute Maximum Ratings.....	12
5.2 Recommended Operating Conditions.....	12
5.3 Radio Characteristics.....	12
5.4 MCU Reset Timing	13
6 Software Overview	14
6.1 Functional Description.....	14
6.2 Software Features	14
7 Power Management	14
7.1 Functional Description.....	14
7.1.1 Power Mode 0---at+pwrmode=0.....	14
7.1.1 Power Mode 1---at+pwrmode=1.....	15
7.1.2 Power Mode 2---at+pwrmode=2.....	15
7.1.3 Power Mode 3---at+pwrmode=3.....	15
7.1.4 Power Mode 4---at+pwrmode=4.....	15
8 Order Information.....	15
8.1 Product Information	15
8.2 Others	15
8.3 Sales and Technical Support	16
9 Revision&History.....	16
9.1 Current.....	16
9.2 History.....	16

1 Overview

1.1 General Description

RAK410 module is an ultra-low power WIFI module that fully supports IEEE 802.11b/g/n wireless standards, with a small package and easy-to-use features. The module supports connecting to devices via UART and SPI interfaces, and is internally integrated TCP / IP protocol stack. Hence it facilitates rapid development. In order to adapt to a variety of application environments, RAK410 module is extended into four sub-types: RAK410A, RAK410B, RAK410-1A, and RAK410-1B.

RAK410A: UART interface, with internal on-board antenna

RAK410B: UART interface, with U-FL connector

RAK410-1A: SPI interface, with internal on-board antenna

RAK410-1B: SPI interface, with U-FL connector

1.2 Applications

- Portable products
- Home appliances and electrical appliances
- Industrial M2M communications
- Warehousing
- Point of Sale Terminals
- Buildings automation
- Logistics and Freight Management
- Home security and Automation
- Medical applications, including patient monitoring, remote diagnostics, etc
- Metering
- Security Cameras & Surveillance Equipment

1.3 Devices Features

- Compliant to IEEE 802.11b/g and single stream 802.11n
- Integrated TCP / IP protocol stack
- Support OPEN, WEP, WPA/WPA2-PSK Encryptions
- Support Station, Ad-Hoc and SoftAP modes
- Support TCP, UDP, HTTP Client protocols
- Support DHCP Server / DHCP Client
- Support AT commands and transparent transmission mode
- Support Web server for configuration
- Host interface through UART and SPI
- Support data flow control on UART interface, maximum rate of 921600bps
- On-board ceramic antenna or U.FL antenna connector

- Operating voltage: 3.3V
- Support five power modes, with the lowest power consumption of 0.5uA
- Small package size: 23.14mm × 28.75mm
- FCC, CE and ROHS compliant

1.4 RAK410 System Block Diagram

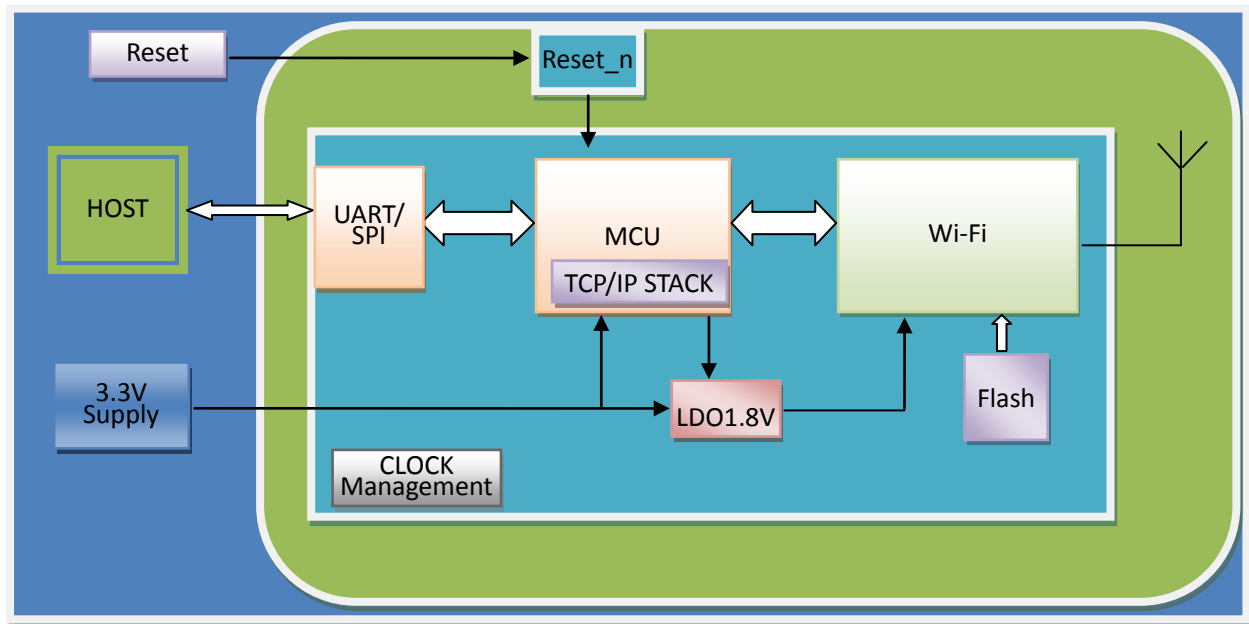

2 Functional Description

2.1 Host Interfaces

● UART

- The UART forms the physical layer of the TCP/IP stack, transferring frames between a Host processor and the module.
- Support variable baud rate from 9600 to 921600bps
- Support hardware flow control
- AT Command Interface for configuring and operating the module

● SPI

- Standard 4-wire SPI, slave mode
- Operating up to a maximum clock speed of 4MHz
- Configurable clock polarity and clock phase

2.2 WLAN

- Compliant to IEEE 802.11b/g/n standards
- Dynamic data rate depending on the channel statistics
- Hardware accelerators for AES
- Support WEP, WPA/WPA2-PSK encryptions
- Support QoS
- Support station, Ad-hoc and SoftAP Modes
- Supports DSSS (1, 2 Mbps) and CCK (5.5, 11 Mbps) modes
- Supports all OFDM data rates (6, 9, 12, 18, 24, 36, 48, and 54 Mbps)
- Supports IEEE 802.11n single-stream modes with data rates up to 65 Mbps
- Supports long, short, and HT preamble modes
- High-performance multipath compensation in OFDM, DSSS, and CCK modes
- Integrated LNA, LPF, Power Amplifier and etc.

2.3 Network Protocols

- TCP
- UDP
- ARP
- ICMP
- DHCP Client
- DHCP Server
- HTTP Client
- Web Server for configuration

2.4 Configuration

The RAK410 module can be configured through UART or SPI. The following are some of the commands that can be given to the module:

- Scan
- Connect
- Pre-shared Keys
- SSID of hidden WLAN networks
- DHCP Enable/Disable
- Create/Join an IBSS network
- Create SoftAP network
- Open/Close sockets for TCP, UDP, Listening TCP

3 Hardware

3.1 Package Dimensions

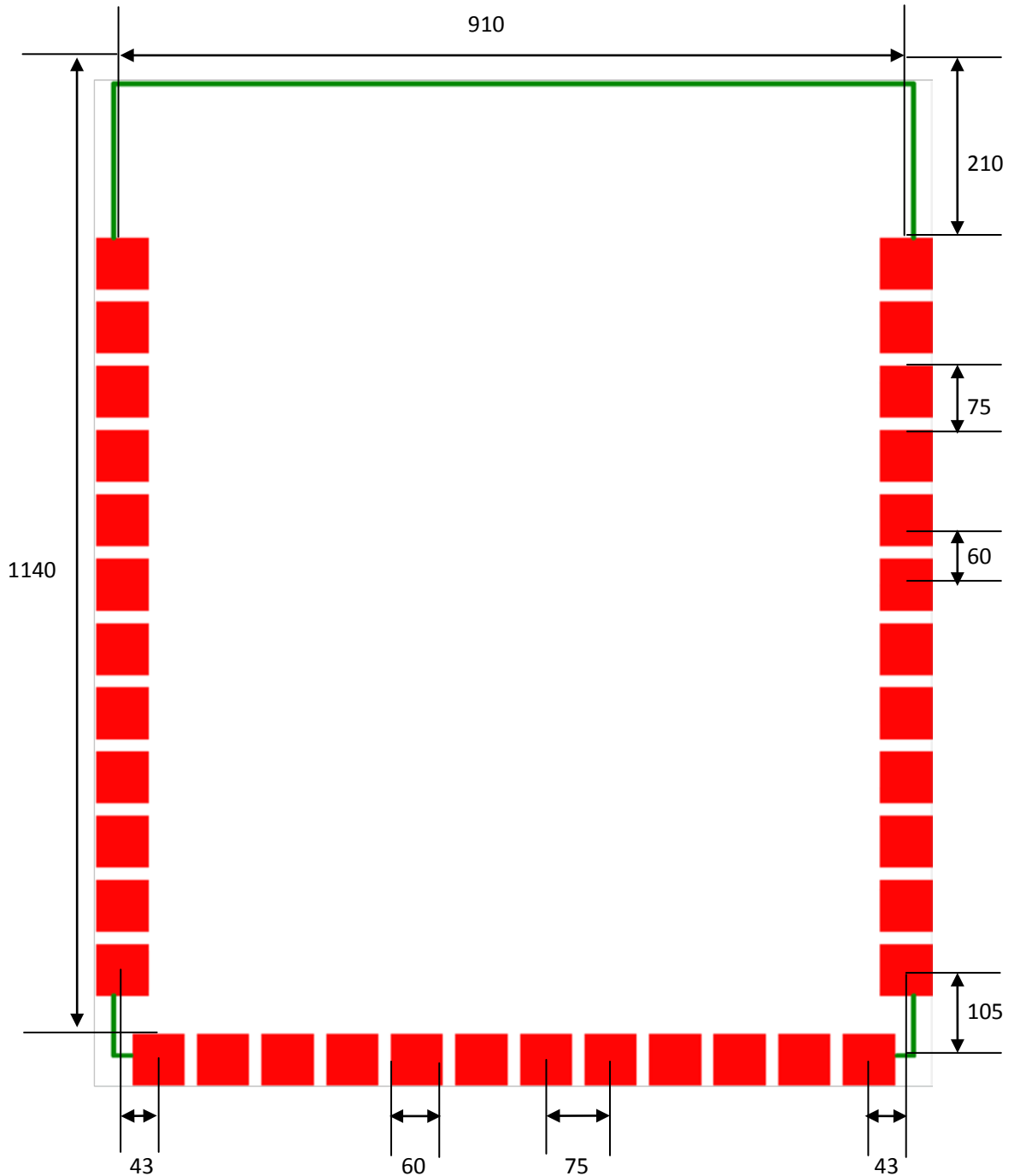
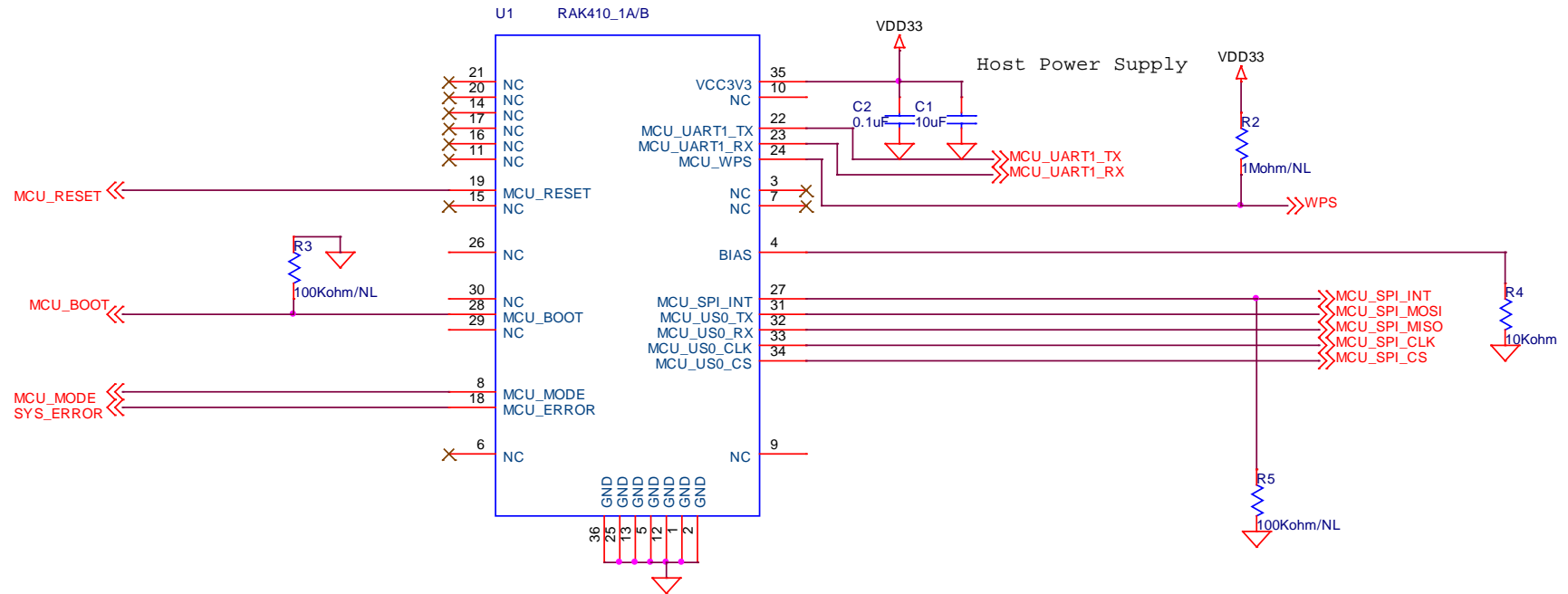

Figure 3-1-1: PCB Pins Size (Bottom View)
(Unit : mil)

3.2 Reference Design

SPI Mode Reference Design



UART Mode Reference Design

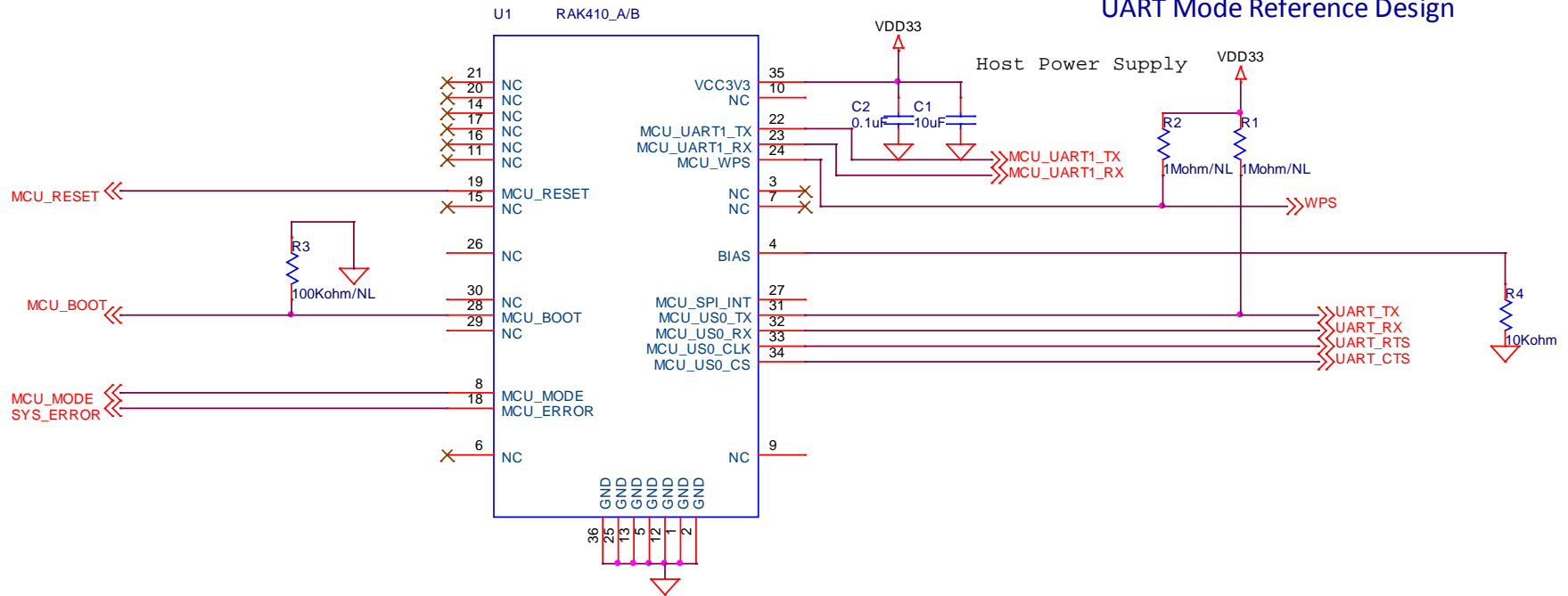

Figure 3-2-1 : RAK410 Module Peripheral Design Reference

Note: R1, R2, R3 are **10kΩ**; C1 is **10µF**; C2 is **0.1µF**.

3.3 Recommended Reflow Profile

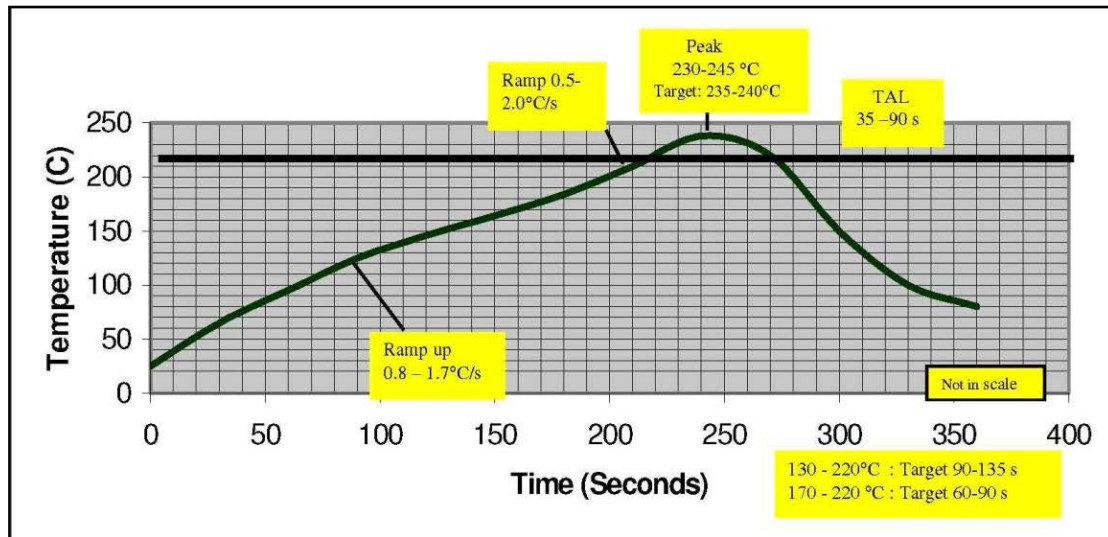

Figure 3-3-1: Reflow Profile

Note: as shown in Figure 3-3-1, the profile shown is based on SAC 305 solder (3% silver, 0.5% copper). We recommend the ALPHA OM-338 lead-free solder paste. This profile is provided mainly for guidance. The total dwell time depends on the thermal mass of the assembled board and the sensitivity of the components on it..

3.4 Baking Instructions

The RAK410 module is moisture sensitive and devices must be handled appropriately. After the devices are removed from their vacuum sealed packs, they should be taken through reflow for board assembly within 168 hours at room conditions, or stored at under 10% relative humidity. If these conditions are not met, the RAK410 module must be baked before reflow. Recommended baking time is 9 hours at 125 °C.

4 Pin Descriptions

4.1 Module Pinout (Top View)

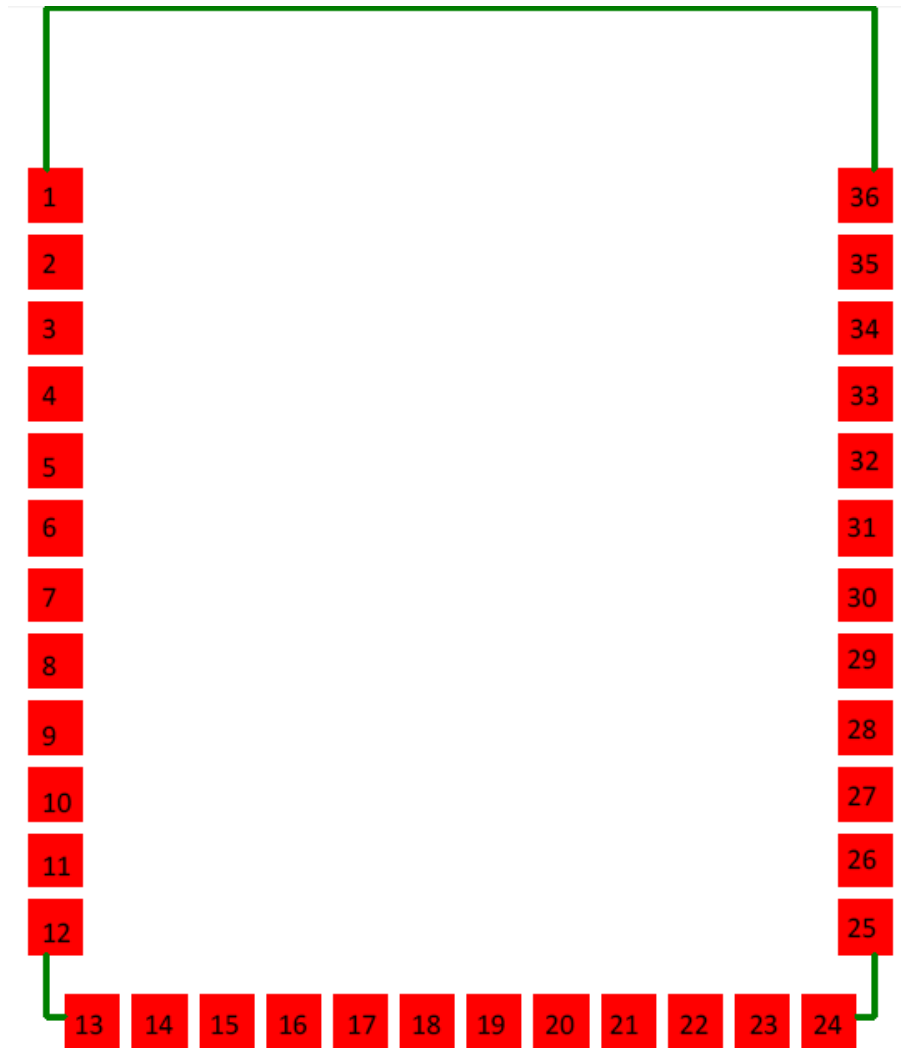

Figure 4-1-1: Module Pins Map

4.2 Pin Description

Pin No.	Name	Description	Type
1	GND	Ground	P
2	GND	Ground	P
3	NC	No connect (Reserved)	-
4	BIAS	Bias pin, 10KΩ resistor to the ground	I
5	GND	Ground	P

6	NC	No connect (Reserved)	-
7	NC	No connect (Reserved)	-
8	MCU_MODE	only effective under the condition "at+storeenable=1" MCU_MODE=1, RAK410 enter into transparent transmission mode MCU_MODE=0, RAK410 enter into AT Command mode	I
9	NC	No connect (Reserved)	-
10	NC	No connect (Reserved)	-
11	NC	No connect (Reserved)	-
12	GND	Ground	P
13	GND	Ground	P
14	NC	No connect (Reserved)	-
15	NC	No connect (Reserved)	-
16	NC	No connect (Reserved)	-
17	NC	No connect (Reserved)	-
18	MCU_ERROR	Report MCU error in Transparent Transmission mode, active high	O
19	MCU_RESET	Module reset, active when the signal is low	I
20	NC	No connect (Reserved)	-
21	NC	No connect (Reserved)	-
22	MCU_UART1_TX	UART TX signal when upgrade Firmware	O
23	MCU_UART1_RX	UART RX signal when upgrade Firmware	I
24	MCU_WPS	Wi-Fi Protected Setup	I
25	GND	Ground	-
26	NC	No connect (Reserved)	-
27	MCU_SPI_INT	SPI Interrupt Signal, active when the signal high, please reserve 100KΩ to GND	-
28	MCU_BOOT	Enter boot loader, active high.	I
29	NC	No connect (Reserved)	-
30	NC	No connect (Reserved)	-
31	MCU_US0_TX	UART mode: MCU_UART_TX, UART data transmit signal	O
		SPI mode: MCU_SPI_MISO, SPI data receive signal	I
32	MCU_US0_RX	UART mode: MCU_UART_TX, UART data receive signal	I
		SPI mode: MCU_SPI_MISO, SPI data transmit signal	O
33	MCU_US0_CLK	UART mode: MCU_UART_RTS, UART RTS signal	O
		SPI mode: MCU_SPI_CLK, SPI clock input signal	I
34	MCU_US0_CS	UART mode: MCU_UART_CTS, UART transmit clear	O
		SPI mode: MCU_SPI_CS, SPI chip select input	I
35	VCC3V3	Operating voltage input (3.3V)	P
36	GND	Ground	P

Table 4-1-1: Pin Definition

5 Electrical Characteristics

5.1 Absolute Maximum Ratings

The following table shows the absolute maximum ratings. Absolute maximum ratings are those values beyond which damage to the device can occur. Functional operation under these conditions, or at any other condition beyond those indicated in the operational sections of this document, is not recommended.

Parameters	Symbols	Value	Unit
External supply voltage	VCC3V3	-0.3~4.0	V
Maximum RF Input (Reference: 50 Ω)	RF _{in}	+10	dBm
When voltage is 3.3V, IO Max voltage	3V3V _{in} IOMax	VCC+0.3	V
When voltage is 3.3V, IO Min voltage	3V3V _{in} IOMin	-0.3	V
Storage ambient temperature	T _{store}	-65~+135	°C
ESD resistance	ESD _{HBM}	2000	V

Table 5-1-1: Absolute Maximum Ratings

5.2 Recommended Operating Conditions

Parameters	Symbols	Min Value	Typical Value	Max Value	Unit
External voltage	V _{cc}	3.14	3.3	3.46	V
Ambient temperature	T _{ambient}	-40	--	+85	°C

Table 5-2-1: Recommended Operating Conditions

5.3 Radio Characteristics

- RF Transmitter Characteristics

Symbol	Parameters	Rate	Typical Value	Unit
F _{tx}	Frequency range	--	2.4	GHz
P _{out}	Output power	--	--	--
	802.11b	1Mbps	17	dBm
	802.11g	6Mbps	17	dBm
	802.11n,HT20	MCS0	17	dBm
	802.11g,EVM	54Mbps	14	dBm
	802.11n,HT20EVM	MCS7	10	dBm

Table 5-3-1: Partial RF Transmit Specifications

● RF Receiver Characteristics

Symbol	Parameters	Test conditions	Typical Value	Unit
Receiver sensitivity	11b,1Mbps		-97	dBm
	11b,2Mbps		-92	dBm
	11b,5.5Mbps		-90	dBm
	11b,11Mbps		-88	dBm
	11g,9Mbps		-91	dBm
	11g,18Mbps		-87	dBm
	11g,36Mbps		-81	dBm
	11g,54Mbps		-75	dBm
	11n,MCS1,13Mbps		-89	dBm
	11n,MCS3,26Mbps		-82	dBm
	11n,MCS5,52Mbps		-75	dBm
	11n,MCS7,65Mbps		-72	dBm
Maximum input signal	CH7	11g,54Mbps	10	dBm
Adjacent channel suppression	6Mbps		37	dBc
	54Mbps		21	dBc
	MCS0		38	dBc
	MCS7		20	dBc

Table 5-3-2: Partial RF Receiver Specifications

5.4 MCU Reset Timing

Figure 5-4-1 shows the MCU reset timing diagram and reset pulse length.

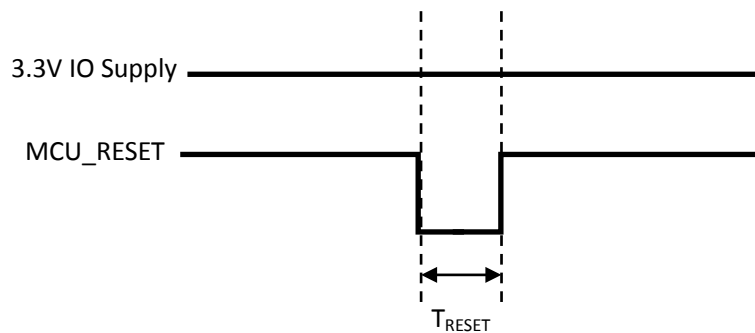

Figure 5-4-1: MCU Reset Timing

Table 5-4-1 shows the description of MCU reset parameters.

Symbol	Description	typical (μS)
T_{RESET}	MCU reset pulse length	100

Table 5-4-1: MCU Reset Parameters

6 Software Overview

6.1 Functional Description

By sending AT commands via UART / SPI, RAK410 completes module configurations, which include wireless network scan, password entering and network connection, establishment of TCP / UDP connection and data transmit.

RAK410 also support configuration by web server.

6.2 Software Features

- ◆ Support TCP, UDP protocols
- ◆ Support PING command
- ◆ Support DHCP SERVER / DHCP CLIENT
- ◆ Support AT command mode and transparent transmission mode when send data
- ◆ Support configuration parameters saving; through pin control, the module can enter directly into the transparent transmission mode after powered
- ◆ Support disconnected TCP automatically reconnection, disconnected wireless automatically reconnection in transparent transmission mode,

7 Power Management

7.1 Functional Description

As the following figure shows, RAK410 supports 5 operating modes:

Mode	Command	Parameter	MCU	Wireless	Wakeup Style	Typical
0	at+pwrmode=0	0	Normal_Mode	Active	No Need	100mA
1	at+pwrmode=1	1	Sleep_Mode	Power_Save	No Need	20mA
2	at+pwrmode=2	2	Sleep_mode	Shut_Down	CMD:at+wake_up	2mA
3	at+pwrmode=3	3	Deep_mode	Power_Save	Interrupt	3mA
4	at+pwrmode=4	4	Deep_mode	Shut_Down	Interrupt	0.5uA

Table 7-1-1: Operating Mode and the Corresponding Power Consumption

7.1.1 Power Mode 0----at+pwrmode=0

In power Mode 0, RAK410 module operates at the best performance, and the wireless and MCU is completely active.

7.1.1 Power Mode 1----at+pwrmode=1

The wireless and MCU enter into low power mode. Host can operate module by AT command, sending and receiving data.

7.1.2 Power Mode 2----at+pwrmode=2

When enter this mode, module saves connection status automatically, power down wireless and MCU enter into low power mode. Host should only use “at+wake_up”, to wake up module and restore operation.

7.1.3 Power Mode 3----at+pwrmode=3

When enter this mode, MCU enter into deep sleep and cannot respond any command, but wireless keeps current connection status. The host can only wake this part via UART_CTS pin or via sending data through wireless to the module,the module enters into mode 1,and operate normallyon.

7.1.4 Power Mode 4----at+pwrmode=4

When enter into this mode, module save current connection status, power down wireless, and then module enters into deep sleep. Module cannot respond any command and wireless data. It have the lowest power consumption. The host can only wake module up via UART_CTS, and restore the power mode before deep sleep.

8 Order Information

8.1 Product Information

Product	OS	Description	Firmware	Standard Package
RAK410A	/	UART interface, internal antenna	WLAN&MCU Firmware	27pcs/pkg
RAK410B	/	UART interface, with U-FL connector	WLAN&MCU Firmware	27pcs/pkg
RAK410-1A	/	SPI interface, internal antenna	WLAN&MCU Firmware	27pcs/pkg
RAK410-1B	/	SPI interface, with U-FL connector	WLAN&MCU Firmware	27pcs/pkg

Table8-1-1 Product Information

8.2 Others

Packaging:Tray vacuum package

Weight: 2.96g/pcs

8.3 Sales and Technical Support

Beijing

FAE e-mail : allan.jin@lthonway.com Allan Jin

Address : Room504,1+1Building, 10# Caihefang Road of Beijing,China

URL : <http://www.lthonway.com/>

Shanghai

FAE e-mail : lee.zhang@lthonway.com Lee.Zhang

Address : Room 412,Hongyi Building, 2158# Wanyuan Road,Minhang District of Shanghai,China.

Shenzhen

FAE e-mail : peter.peng@lthonway.com Peter.Peng

Address : 393#,Jihua Road,Shangxue Section,Buji,Shenzhen 518129, China

9 Revision&History

9.1 Current

V1.0.7	Released	2013-09-04
--------	----------	------------

9.2 History

Revision	Update	Date
V1.0.7	Update order information	2013-09-04