

Typical Features

- ◆ Fixed input voltage, Isolated & unregulated output, Output power 1W
- ◆ High Efficiency up to 78%
- ◆ Small compact SIP packing
- ◆ No external component required
- ◆ Isolation Voltage 1500VDC
- ◆ Operating Temperature: -40℃~+85℃
- ◆ Plastic Case, meet UL94-V0 standard



Test Condition: Unless otherwise specified, data in the datasheet should be tested under the conditions of inputting nominal voltage, pure resistance rated load and Ta=25℃

Application Field

It could be widely used for instrument, communication, pure digital circuit, general low frequency analog circuit, relay drive circuit, data exchange circuit, etc.

Typical Product List

Model	Input Voltage Range (VDC)		Output Voltage/Current (Vo/Io)		Input Current(mA) Nominal Voltage		Max. Capacitive Load uF	Ripple & Noise (Max.) mVp-p	Efficiency (%)full load, input nominal voltage	
	Nominal	Range	Voltage (VDC)	Current(mA) MAX./Min.	Full load Typ.	No Load Typ.			Min.	Typ.
FN1-3V3S3V3BN	3.3	3.0 - 3.6	3.3	300	421	40	47	100	70	72
FN1-3V3S05BN			5	200	410	40	47	100	72	74
FN1-3V3S09BN			9	110	410	40	22	100	72	74
FN1-3V3S12BN			12	83	410	40	22	100	72	74
FN1-3V3S15BN			15	67	410	40	22	100	72	74
FN1-05S3V3BN	5	4.5 - 5.5	3.3	300	270	30	47	100	72	74
FN1-05S05BN			5	200	263	30	47	100	74	76
FN1-05S09BN			9	110	260	30	22	100	75	77
FN1-05S12BN			12	83	260	30	22	100	75	77
FN1-05S15BN			15	67	256	30	22	100	76	78
FN1-05S24BN			24	42	260	30	10	120	75	77
FN1-09S3V3BN	9	8.1 - 9.9	3.3	300	150	22	47	100	72	74
FN1-09S05BN			5	200	146	22	47	100	74	76
FN1-09S09BN			9	110	144	22	22	100	75	77
FN1-09S12BN			12	83	144	22	22	100	75	77

FN1-09S15BN			15	67	144	22	22	100	75	77
FN1-09S24BN			24	42	146	22	10	120	74	76
FN1-12S3V3BN	12	10.8 - 13.2	3.3	300	113	16	47	100	72	74
FN1-12S05BN			5	200	108	16	47	100	75	77
FN1-12S09BN			9	110	108	16	22	100	75	77
FN1-12S12BN			12	83	108	16	22	100	75	77
FN1-12S15BN			15	67	107	16	22	100	76	78
FN1-12S24BN			24	42	108	16	10	120	72	74
FN1-15S3V3BN			15	13.5 - 16.5	3.3	300	90	12	47	100
FN1-15S05BN	5	200			88	12	47	100	74	76
FN1-15S09BN	9	110			88	12	22	100	75	77
FN1-15S12BN	12	83			87	12	22	100	75	77
FN1-15S15BN	15	67			87	12	22	100	74	76
FN1-15S24BN	24	42			88	12	10	120	72	74
FN1-24S3V3BN	24	21.6 - 26.4	3.3	300	57	8	47	100	71	73
FN1-24S05BN			5	200	55	8	47	100	74	76
FN1-24S09BN			9	110	54	8	22	100	75	77
FN1-24S12BN			12	83	54	8	22	100	75	77
FN1-24S15BN			15	67	53	8	22	100	76	78
FN1-3V3D05BN	3.3	3.0 - 3.6	±5	±100	410	40	22	100	72	74
FN1-3V3D09BN			±9	±55	410	40	10	100	72	74
FN1-3V3D12BN			±12	±42	410	40	10	100	72	74
FN1-3V3D15BN			±15	±33	410	40	10	100	72	74
FN1-05D05BN	5	4.5 - 5.5	±5	±100	263	30	22	100	74	76
FN1-05D09BN			±9	±55	260	30	10	100	75	77
FN1-05D12BN			±12	±42	260	30	10	100	75	77
FN1-05D15BN			±15	±33	256	30	10	100	76	78
FN1-05D24BN			±24	±21	260	30	4.7	120	75	77
FN1-09D05BN	9	8.1 - 9.9	±5	±100	146	22	22	100	74	76
FN1-09D09BN			±9	±55	144	22	10	100	75	77
FN1-09D12BN			±12	±42	144	22	10	100	75	77
FN1-09D15BN			±15	±33	144	22	10	100	75	77
FN1-09D24BN			±24	±21	146	22	4.7	120	74	76
FN1-12D05BN	12	10.8	±5	±100	108	16	22	100	75	77

FN1-12D09BN	-	13.2	±9	±55	108	16	10	100	75	77
FN1-12D12BN			±12	±42	108	16	10	100	75	77
FN1-12D15BN			±15	±33	107	16	10	100	76	78
FN1-12D24BN			±24	±21	108	16	4.7	120	75	77
FN1-15D05BN	15	13.5	±5	±100	88	12	22	100	74	76
FN1-15D09BN			±9	±55	88	12	10	100	74	76
FN1-15D12BN		-	±12	±42	87	12	10	100	75	77
FN1-15D15BN		16.5	±15	±33	87	12	10	100	75	77
FN1-15D24BN		±24	±21	88	12	4.7	120	74	76	
FN1-24D05BN	24	21.6	±5	±100	55	8	22	100	74	76
FN1-24D09BN			±9	±55	54	8	10	100	75	77
FN1-24D12BN		-	±12	±42	54	8	10	100	75	77
FN1-24D15BN		26.4	±15	±33	53	8	10	100	76	78

- Note:
1. “*” are models under developing.
 2. In order to ensure the converter can work reliably with high efficiency, the minimum load should not less than 10% rated load when it is used. If the needed power is indeed small, please parallel a resistor at the output side, the resistance recommended equal to 10% nominal power.
 3. The capacitive loads of positive and negative outputs are identical.

Input Specifications

Item	Test Condition	Min.	Typ.	Max.	Unit
Input Overshoot Voltage (1Second.max.)	3.3Vdc Input	-0.7	-	7	VDC
	5Vdc Input	-0.7	-	9	
	12Vdc Input	-0.7	-	18	
	15Vdc Input	-0.7	-	21	
	24Vdc Input	-0.7	-	30	
Input Filter	Capacitor Filter				

Output Specifications

ITEM	Working Conditions	Min.	Typ.	Max.	Unit
Output Power		0.1	--	1	W
Output Voltage Accuracy	Nominal input, Full load	--	±2	±5	%
Load Regulation	10% ~ 100% nominal load	3.3Vdc output	--	20	
		Other output	--	15	
Line Voltage Regulation	Input Voltage	3.3Vdc output	--	±1.5	

	Change±1%	Other output	--	--	±1.2	
Ripple & Noise①	Nominal input,full load, 20MHZ bandwidth	Other output	--	75	100	mVp-p
		24Vdc output	--	100	120	
Temperature Drift Coefficient	100% Full Load		--	--	±0.03	%/°C
Output Short Circuit Protection②	Continuous short-circuit protection, self-recovery					

NOTE:①Ripple & Noise tested by twisted-pair method,

General Specifications

Switching Frequency	typical	100KHz (Typ.)
Operating Temperature	Refer to Temperature Derating Curve	-40°C ~ +85°C
Storage Temperature		-55°C ~ +125°C
Shell temperature rise during work	Within Temperature Derating Curve	25°C
Relative Humidity	No condensing	5%~95%
Case Material		Black flame-retardant heat-resistant Plastic(UL94-V0)
Product Weight		2.4g(Typ.)
Isolation Voltage	Test 1 minute, leakage current < 0.5mA	1500Vdc ≤ 0.5mA / 1min
Isolation Capacitor	Input/Output,100KHz/0.1V	20 pF (Typ.)
MTBF	MIL-HDBK-217F@25°C	35X10 ⁵ Hrs

Packing Dimension

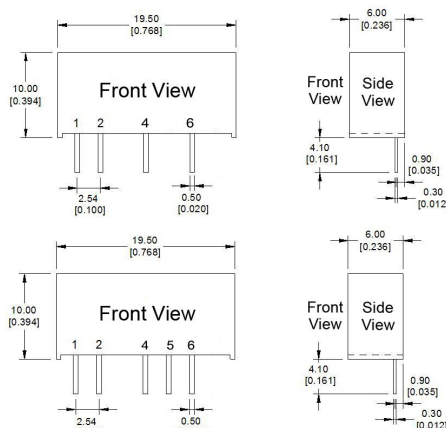

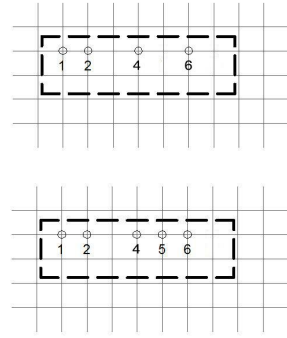

Print board vertical view
Grid: 2.54mm(0.1inch)

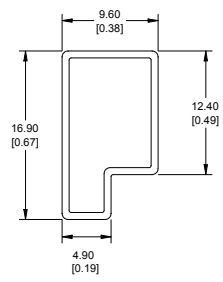

Note:
Unit: mm[inch]
General tolerance: x.xx±0.5mm[x.xx±0.020 inch]
x.x±0.2mm[x.x±0.008 inch]

Packing Code	L x W x H	
B	19.50 × 6.00 × 10.00mm	0.768 × 0.236 × 0.394inch

Pin Function

Pin Function	1	2	3	4	5	6
Single(S)	+Vin	GND	NP	-Vo	NP	+Vo
Dual(D)	+Vin	GND	NP	-Vo	COM	+Vo

Note: if the definition of pin is not in accordance with the model selection manual, please refer to the label on actual item.

Ripple & Noise Test: (Twisted Pair Method 20MHz bandwidth)

Test Method:

a. 12# twisted pair to connect, Oscilloscope bandwidth set as 20MHz, 100M bandwidth probe, terminated with 0.1uF polypropylene capacitor and 10uF high frequency low resistance electrolytic capacitor in parallel, oscilloscope set as Sample pattern.

b. Input terminal connect to power supply, output terminal connect to electronic load through jig plate, Use 30cm±2 cm sampling line, Power line selected from corresponding diameter wire with insulation according to the flow of output current.

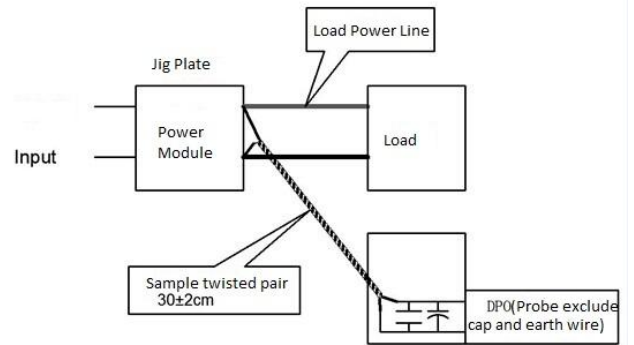

Temperature Curve

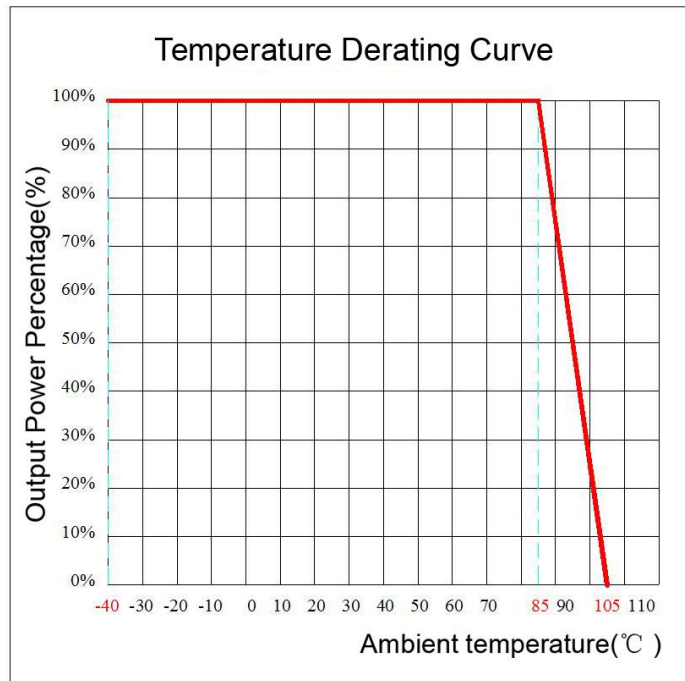

/

Design and Application Circuit Recommended

1. Output load requirements

- a. In order to ensure the converter can work reliably with high efficiency, the minimum load should not less than 10% rated load when it is used. If the needed power is indeed small, please parallel a resistor at the output side, the resistance equal to 10% nominal load.
- b. The maximum capacitive load is tested under nominal input full load, and cannot exceed the maximum capacitive load of output terminal under operation, otherwise it will cause it difficult to start up and damage the product.

2. Recommended circuit

In order to ensure the input/output ripple and noise decreased, capacitor filter net could be connected to input and output terminal, application circuit as below photo 1; choosing suitable filter capacitor is very important, start-up problems may be caused by too large capacitance. To ensure the modules running safely and reliably, the recommended capacitive load values as shown in Table 1. (But for the actual output power of application circuit is less than 0.5W, suggest not to connect external capacitor)

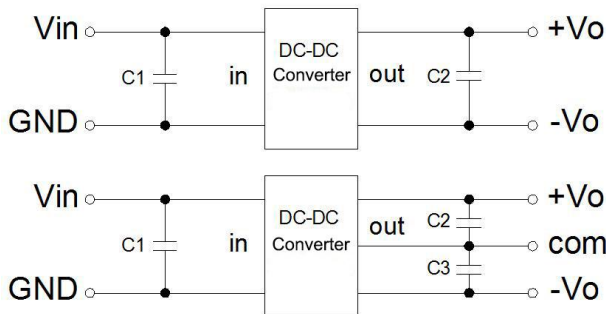

Recommended capacitive load value(Table 1)

Vin (Vdc)	C1 (μF)	Vout (Vdc)	C2 (μF)	Vout (Vdc)	C2,C3 (μF)
3.3/5	4.7	3.3/5	10	±3.3/±5	4.7
12	2.2	9	4.7	±9	2.2
15	1	12	2.2	±12	1
24	1	15	1	±15	0.47
--	--	24	0.47	±24	0.22

3. Output regulated voltage and over voltage protection circuit

The simplest device to protect output regulated voltage, over voltage and over current is to cascade a linear regulator with overheat protection at input or output terminal, and connect a capacitor filter net(see below picture), filter capacitive value recommended see table 1, Linear regulator is chosen according to the actual voltage, current needed in working, or choose our NW series products.

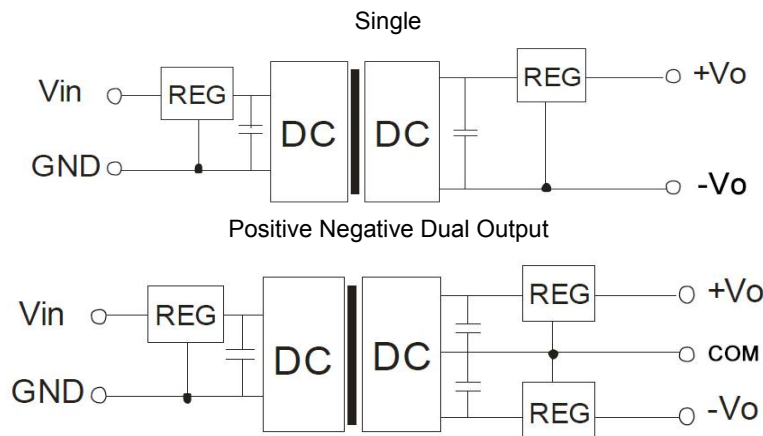

Note:

- 1.This product cannot be used in parallel, and do not support hot-plugging;
- 2.If the product works below the minimum required load, it cannot guarantee that the product performance meets all performance indicators in this manual;
3. All index testing methods in this datasheet are based on our Company's corporate standards
4. The product specification may be changed at any time without prior notice.